

HIGH PRECISION GEARED
SERVO MOTORS
RDrive 50

USER MANUAL



INTRODUCTION

Rozum Robotics has designed its RDrive (RD) servo motors to enable precision motion control in industrial and commercial applications.

This manual is intended for technicians and engineers who design, build, and operate systems and machinery that use RDrive servo motors for actuation. In this document, you will find the following information:

- basic features and components of RDrive servo motors
- requirements on additional equipment for correct and safe operation of RDrive servo motors
- specifications of the RD50 servo motor, as well as its allowable radial and axial loads
- requirements and instructions on mechanical and electrical integration of the RD50 servo motor
- instructions and recommendations on implementing motion control of RDrive servos
- maintenance, transportation, and storage recommendations

WARNING SIGNS AND THEIR MEANINGS

Below, you can see the warning symbols used throughout the manual and their meaning.



The sign denotes important information that is not directly related to safety, but that the user should be aware of.



The sign indicates important safety precautions the user should follow.

TABLE OF CONTENTS

INTRODUCTION	2
WARNING SIGNS AND THEIR MEANINGS	2
1. PRODUCT OVERVIEW	4
1.1. Basic features and components	4
1.2. Required additional equipment	5
1.3. Intended use and operating conditions	5
2. PRODUCT SPECIFICATIONS	6
2.1. Specifications of the RD50 servo motor	6
2.2. Allowable axial and radial loads	7
3. MOTION CONTROL	7
3.1. Motion control principle	7
3.2. Motion feedback	8
3.3. Motion control implementation	8
3.3.1. CANOpen communication	8
3.3.2. User API	8
4. INTEGRATION INTO AN APPLICATION	9
4.1. Installation requirements	9
4.2. Installation procedure	9
4.2.1. Preparation	10
4.2.2. Mechanical integration	10
4.2.3. Power supply and CAN connections	12
4.2.4. Pre-commissioning checks	12
5. MAINTENANCE	12
6. TROUBLESHOOTING	13
7. TRANSPORTATION AND STORAGE	13

1. PRODUCT OVERVIEW

1.1. Basic features and components

RDrive servo motors are intended to ensure high-precision rotary motion. Their *basic features* are as follows:

- a compact hollow-shaft design allowing for easy integration
- a built-in strain-wave gearhead with an almost-zero backlash
- an integrated controller supporting CAN communication
- two 19-bit absolute magnetic encoders providing motion feedback

Figure 1-1 is an exploded view of an RDrive servo motor in a housing.

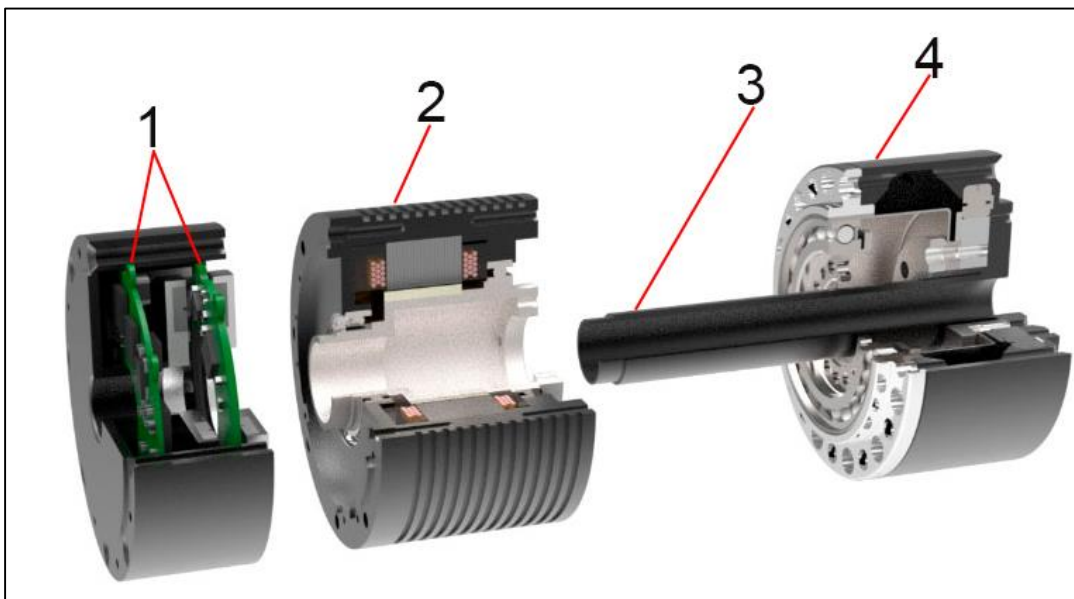

Figure 1-1: The components of an RDrive servo motor

(1)	Two printed circuit boards (PCBs) connected with each other by means of a BiSS line (not visible in Figure 1-1). One of the PCBs incorporates a controller and the other—two encoders.
(2)	A frameless brushless alternating current (AC) motor comprising a rotor and a stator, as well as a negative temperature coefficient (NTC) thermistor (fitted into the stator winding).
(3)	A hollow shaft for laying the cables to connect the servo to a machine.
(4)	A strain-wave gearhead that reduces rotation speed (RPM) and increases motor torque.

By design, the RDrive servo motor also comprises a **cable gland** (not visible in Figure 1-1) located on its rear flange (see Figure 4-1). The gland includes four wires:

- two wires for connecting the servo to power supply
- two wires for enabling CAN communication

1.2. Required additional equipment

For **safe and correction operation** of RDrive servo motors, **it is obligatory** to integrate the following components into their power supply circuit:

- at least one **energy eater** to dissipate dynamic braking energy



When not dissipated, dynamic braking energy can cause servos to generate voltages in excess of the power supply voltage, which can damage servos beyond repair.

- at least one **capacitor** to compensate for short-term power consumption peaks due to inductive resistance

Rozum Robotics combined the two components into its **servobox solution** you can order as an option. For more information about the solution, refer to the [Rozum Robotics Servobox Manual](#).

Alternatively, you can assembly a similar solution from third-party components on your own, following the recommendations in the [Rozum Robotics Servobox Manual](#).

1.3. Intended use and operating conditions

RDrive motors are designed for industrial and commercial use. Possible applications are as follows:

- robots or drones
- model aircrafts
- conveyor belts, sorting and assembly lines
- packing equipment
- solar batteries
- metal-cutting, molding, woodworking, and other industrial machines
- rotary antennas
- automated door-opening mechanisms (doors, gates, etc.)
- 3D printers
- and other mechanisms where you need to provide high-precision rotary motion

Inadmissible applications include explosive or otherwise hazardous areas, as well as locations with highly corrosive atmospheres.

Table 1-1: Operating conditions of RDrive servo motors

Parameter	Value
Altitude	Not higher than 1,000 m above the sea
Operating temperature	0°C to +35°C
Operating humidity	80% max at 25°C (90% at 20°C)
IP protection	IP20



Avoid exposing servo motors to any operating conditions outside of the above specifications. This can damage their components and/or reduce their service life.

2. PRODUCT SPECIFICATIONS

2.1. Specifications of the RD50 servo motor

Table 2-1 contains performance, electrical, and mechanical specifications, as well as dimensions of the RD50 servo motor.

Table 2-1: Specifications of the RDrive 50 servo motor

PERFORMANCE DATA		
Rated rotation speed	55	RPM
RMS current	1.6	A
Rated torque	11	N·m
Peak torque	28	N·m
Torque constant (Kt) at 20°C	74	mN·m/A
Service life	35,000	hours
ELECTRICAL DATA		
Rated power	65	W
Supply voltage	48	V
MECHANICAL DATA		
Motor inertia	0.022	kg·cm ²
Weight	0.6	kg
IP rating	IP21*	
DIMENSIONS		
Length (L):	85	mm
Diameter (D):	53	mm
Hollow shaft diameter (d):	9	mm

*Upon request, RDrive servo motors can be supplied with a higher IP rating.

In Table 2-2, you will find basic specifications of the gearhead integrated into the RDrive servo.

Table 2-2: The RDrive gearhead data

GEARHEAD DATA		
Gearhead type	Strain-wave	
Gearhead ratio	1:100	
Gearhead backlash	0.3	arcmin

2.2. Allowable axial and radial loads

The gearhead in the RDrive servo motor incorporates a high-rigidity crossed roller bearing to support output loads. The bearing can withstand high axial and radial forces, as well as high tilting moments. It keeps the gearhead protected from external loads, which guarantees long life and consistent performance of the gearhead.

Table 2-3 lists allowable axial and radial loads for the RD50 servo motor.

Table 2-3: Allowable axial and radial loads for the RD50 servo

Allowable axial load, F_a [N] ¹⁾²⁾	700
Allowable radial load, F_r [N] ¹⁾²⁾	460

¹⁾ These data are valid for $n=15$ RPM and $L_{lo} = 25,000$ h, where L_{lo} is the operating life of the output bearing.

²⁾ These data are valid, only provided the following conditions are met:

For:

- **Fa:** $M = 0$; **Fr** = 0;

- **Fr:** $M = 0$; **Fa** = 0,

where **M** is the tilting moment.

3. MOTION CONTROL

3.1. Motion control principle

The motion control system of RDrive servo motors is of the closed-loop type: it not only receives motion control commands from a control device, but also provides feedback on their execution. The system consists of a self-designed controller and two encoders (see Section 3.2).

The operation of the motion control system involves the following interactions:

- The controller receives a control command from a control device (e.g., a PC or a CAN master) and applies current to the frameless AC motor to produce motion with required parameters.
- The two encoders monitor the absolute positions of the rotor and output shaft and send feedback to the controller.
- The controller processes the feedback and compares the resulting values with the control command. If needed, it also adjusts the motor position and other parameters.
- In addition, the controller receives and processes feedback signals from the NTC thermistor in the motor winding. When the value based on the thermistor reading exceeds the maximum temperature limit, the controller cuts the servo off.

3.2. Motion feedback

RDrive servo motors comprise two integrated feedback devices—absolute magnetic encoders. The two encoders are mounted on a separate PCB that is connected with the controller PCB by means of a flat cable (a BiSS line). One of the encoders delivers information about the absolute position of the output shaft and the other—about that of the rotor.

Table 3-1: Encoder data

Type	rotary magnetic single-turn
Output	absolute position
Resolution	19-bit

3.3. Motion control implementation

You can implement motion control of RDrive servo motors in either of the two ways:

- based on CANOpen communication
- via Application Programming Interface (API)

3.3.1. CANOpen communication

CANOpen communication implemented for RDrive servos relies on the Controller Area Network (CAN) for its physical infrastructure. CAN is a two-wire bus line that transmits differential signals—CAN_{HIGH} and CAN_{LOW}.



A CAN bus line enables to control multiple RDrive servos from a single device. The maximum admissible number of devices on a single bus is 127.



For CAN connection requirements and schematic, refer to the [Rozum Robotics Servobox Manual](#).

On a higher level, CANOpen communication for RDrive servos is implemented as a stack of CANOpen protocols. The protocols monitor the network states and transmit and/or read CAN data frames containing various types of data (e.g., commands, parameters, servo telemetry) in the binary format. For a detailed description of the CANOpen communication interface implemented for RDrive servos and related application cases, refer to “**RDrive Servo Motors. CANOpen Communication Guide.**”

3.3.2. User API

For enabling motion control of RDrive servos via API, you will need the following:

- an appropriate CAN connection

For CAN connection requirements and schematic, refer to the [Rozum Robotics Servobox Manual](#) (also available for downloading at <https://rozum.com/support/docs/servo-api/RR-UserAPI.pdf>).

- a CAN-USB dongle and a standard Micro USB-USB A cable to connect the dongle to your control computer

The CAN-USB dongle can be supplied as an option upon request or as part of the servobox solution. Otherwise, it is at the user's discretion how to provide it.



If your PC runs Windows 8 or earlier versions of the operating system, you will need to download and install a driver to be able to work with the CAN-USB dongle from the servobox supply package. For the downloading link and installation instructions, go to the webpage:

<https://www.st.com/en/development-tools/stsw-stm32102.html>.

- a special software library to be installed on your computer

The library is written in the C language and is available for downloading at the following GitHub repository: <https://github.com/rozum-robotics/Rozum-Servo-Drives-API>. In the repository, you will also find wrappers for Java, Python, and Ruby, as well as compilation and installation requirements and instructions.

For details of controlling RDrive motors with API function calls and tutorials with sample programs, refer to the [User API Guide for RDrive Servo Motors](#) (also available for downloading at: <https://rozum.com/support/docs/servo-api/RR-UserAPI.pdf>).

4. INTEGRATION INTO AN APPLICATION

4.1. Installation requirements



Magnetic-sensitive objects, such as banking cards, pacemakers, or other magnetic information carriers, should be kept away at a distance of 1m from the motor.

RDrive servo motors are intended for installation as part of a motion system or a machine and can be mounted in any required position (e.g., vertical, horizontal, or at an angle). The installation site should meet the following requirements:

- Well-ventilated and free from dust, moisture, and vibration
- Ambient temperature, altitude, and other environmental conditions as specified in Table 1-1
- Easy access for inspection and dismantling

4.2. Installation procedure

The procedure for installing an RDrive servo motor includes the following steps:

1. Preparing for installation

2. Mechanical integration
3. Connecting to power supply
4. Providing CAN connection
5. Pre-commissioning checks

4.2.1. Preparation

To prepare a servo for installation, follow the sequence below:

1. Unpack the servo motor.



Never handle servo motors by cables!



Make sure to avoid any shocks as this can damage high-precision encoders inside servos.

2. Check the fitting surfaces of both the servo and the machine for visible damages.



Using damaged servos is forbidden because it can result in unintended operation of the machine and endanger the operator.

3. Clean the fitting surfaces with a lint-free cloth and a suitable cleaning agent, if needed, and degrease them.

4.2.2. Mechanical integration

For mechanical integration, proceed as below:

1. Align the shaft center of the servo motor with that of the machine. Alignment accuracy is essential to prevent vibration that can damage the output shaft, bearings, or encoders.



Allow for sufficient clearance around the servo for proper heat dissipation.

2. Fasten the servo to the machine. To do this, insert eight M3 screws into the holes on the rear mounting flange and tighten them to the torque of 2.6 N·m max (see Figure 4.1).
3. Screw a load down to the output flange using the twelve M2.5 holes and applying the torque of 1.4 N·m max (see Figure 4.1).



Make sure not to apply excessive impact or force to the output flange.

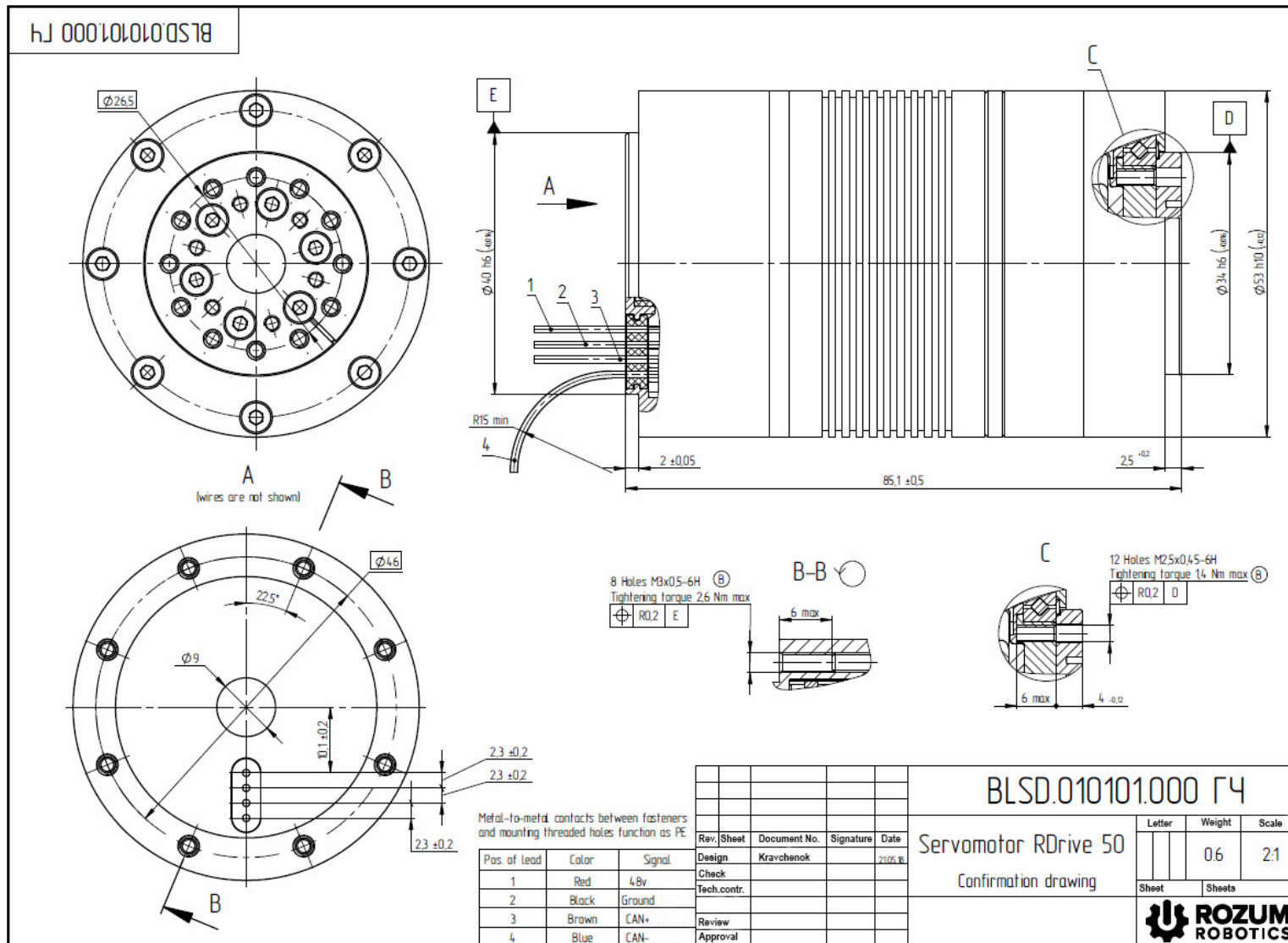

Figure 4-1: The installation drawing for the RD50 servo motor

4.2.3. Power supply and CAN connections



Before starting any wiring works, make sure that no power is supplied to the circuit you are assembling.

The wiring of RDrive servo motors comprises:

- two wires for connecting servos to power supply
- two wires for enabling CAN communication

For the color scheme, cable arrangement, and protective earthing, refer to Figure 4-1.



For correct and safe operation of RDrive servo motors, their power supply circuit should include at least one energy eater and one capacitor (refer to Section 1.2). For more details and related requirements, refer to the [Rozum Robotics Servobox Manual](#).

For requirements and instructions to provide CAN and power supply connections, refer to the [Rozum Robotics Servobox Manual](#).

4.2.4. Pre-commissioning checks

Before commissioning a servo, it is advisable to check whether the following is up to requirements:

- Mechanical integration (refer to Section 4.2.2)
- Electrical integration (see Section 4.2.3):
 - protective earthing (see Figure 4.1)
 - tight connection and integrity of power supply and communication wires
 - at least one energy eater and one capacitor integrated into the supply circuit of the servo (see Section 1.2 and the [Rozum Robotics Servobox Manual](#))
- CAN connection (refer to the [Rozum Robotics Servobox Manual](#))
- Operating conditions (refer to Table 1-1 and Section 4.1)

5. MAINTENANCE

RDrive servo motors contain no parts that a user needs to service. Therefore, the maintenance scope is limited to the following:

- Visual inspection of electrical connections for damages
- Checking screw connections and tightening the loosened ones
- Monitoring vibration and noise levels, as well as heating during daily operation



The above-listed maintenance procedures are not mandatory. It is up to the user to decide to follow the recommendations or not, depending on the application-specific conditions (e.g., whether a servo is accessible for visual inspection).

6. TROUBLESHOOTING

Table 6-1 describes the most common problems that can occur during operation of RDrive servo motors, their possible causes, and recommended user actions.

Table 6-1: Possible servo problems, their causes, and recommended actions

Problem	Possible cause	Recommended action
The motor won't start.	Improper connection.	Check the motor connections.
	Incorrect motor control settings.	Check the motor control settings or contact our service department.
The motor is overheating.	Excessive accumulation of dirt.	Clean the outside of the motor.
	Ambient temperature is too high.	Provide adequate cooling.
	Air pressure is too low because of the altitude.	Provide adequate cooling.
	The motor is too hot.	Check the power supply is up to the specifications (Table 2-1) or contact our service department.
Increased noise during operation.	Damaged bearing.	Contact our service department.
Sporadic failure.	Damaged cable.	Contact our service department.



Only qualified service personnel can perform repair works.

7. TRANSPORTATION AND STORAGE

For transporting the RDrive servo motor, always use the original packaging. In case you have no plans to put the servos into operation immediately upon delivery, make sure to meet the following storage requirements:

- Store servo motors in a dry, dust- and vibration-free location.
- The admissible storage temperature range—from +5°C to +40°C.
- The storage humidity should be 80% max at 25°C (90% at 20°C).